

User's Manual



MPA 152

Mini Power Amplifier

68-1320-01
Rev. A
02 09

Precautions

Safety Instructions • English



This symbol is intended to alert the user of important operating and maintenance (servicing) instructions in the literature provided with the equipment.



This symbol is intended to alert the user of the presence of uninsulated dangerous voltage within the product's enclosure that may present a risk of electric shock.

Caution

Read Instructions • Read and understand all safety and operating instructions before using the equipment.

Retain Instructions • The safety instructions should be kept for future reference.

Follow Warnings • Follow all warnings and instructions marked on the equipment or in the user information.

Avoid Attachments • Do not use tools or attachments that are not recommended by the equipment manufacturer because they may be hazardous.

Consignes de Sécurité • Français



Ce symbole sert à avertir l'utilisateur que la documentation fournie avec le matériel contient des instructions importantes concernant l'exploitation et la maintenance (réparation).



Ce symbole sert à avertir l'utilisateur de la présence dans le boîtier de l'appareil de tensions dangereuses non isolées posant des risques d'électrocution.

Attention

Lire les instructions • Prendre connaissance de toutes les consignes de sécurité et d'exploitation avant d'utiliser le matériel.

Conservier les instructions • Ranger les consignes de sécurité afin de pouvoir les consulter à l'avenir.

Respecter les avertissements • Observer tous les avertissements et consignes marqués sur le matériel ou présents dans la documentation utilisateur.

Eviter les pièces de fixation • Ne pas utiliser de pièces de fixation ni d'outils non recommandés par le fabricant du matériel car cela risquerait de provoquer certains dangers.

Sicherheitsanleitungen • Deutsch



Dieses Symbol soll dem Benutzer in der im Lieferumfang enthaltenen Dokumentation besonders wichtige Hinweise zur Bedienung und Wartung (Instandhaltung) geben.



Dieses Symbol soll den Benutzer darauf aufmerksam machen, daß im Inneren des Gehäuses dieses Produktes gefährliche Spannungen, die nicht isoliert sind und die einen elektrischen Schock verursachen können, herrschen.

Achtung

Lesen der Anleitungen • Bevor Sie das Gerät zum ersten Mal verwenden, sollten Sie alle Sicherheits- und Bedienungsanleitungen genau durchlesen und verstehen.

Aufbewahren der Anleitungen • Die Hinweise zur elektrischen Sicherheit des Produktes sollten Sie aufbewahren, damit Sie im Bedarfsfall darauf zurückgreifen können.

Befolgen der Warnhinweise • Befolgen Sie alle Warnhinweise und Anleitungen auf dem Gerät oder in der Benutzerdokumentation.

Keine Zusatzgeräte • Verwenden Sie keine Werkzeuge oder Zusatzgeräte, die nicht ausdrücklich vom Hersteller empfohlen wurden, da diese eine Gefahrenquelle darstellen können.

Instrucciones de seguridad • Español



Este símbolo se utiliza para advertir al usuario sobre instrucciones importantes de operación y mantenimiento (o cambio de partes) que se desean destacar en el contenido de la documentación suministrada con los equipos.



Este símbolo se utiliza para advertir al usuario sobre la presencia de elementos con voltaje peligroso sin protección aislante, que puedan encontrarse dentro de la caja o alojamiento del producto, y que puedan representar riesgo de electrocución.

Precaución

Leer las instrucciones • Leer y analizar todas las instrucciones de operación y seguridad, antes de usar el equipo.

Conservar las instrucciones • Conservar las instrucciones de seguridad para futura consulta.

Obedecer las advertencias • Todas las advertencias e instrucciones marcadas en el equipo o en la documentación del usuario, deben ser obedecidas.

Evitar el uso de accesorios • No usar herramientas o accesorios que no sean específicamente recomendados por el fabricante, ya que podrían implicar riesgos.

Warning

Power sources • This equipment should be operated only from the power source indicated on the product. This equipment is intended to be used with a main power system with a grounded (neutral) conductor. The third (grounding) pin is a safety feature, do not attempt to bypass or disable it.

Power disconnection • To remove power from the equipment safely, remove all power cords from the rear of the equipment, or the desktop power module (if detachable), or from the power source receptacle (wall plug).

Power cord protection • Power cords should be routed so that they are not likely to be stepped on or pinched by items placed upon or against them.

Servicing • Refer all servicing to qualified service personnel. There are no user-serviceable parts inside. To prevent the risk of shock, do not attempt to service this equipment yourself because opening or removing covers may expose you to dangerous voltage or other hazards.

Slots and openings • If the equipment has slots or holes in the enclosure, these are provided to prevent overheating of sensitive components inside. These openings must never be blocked by other objects.

Lithium battery • There is a danger of explosion if battery is incorrectly replaced. Replace it only with the same or equivalent type recommended by the manufacturer. Dispose of used batteries according to the manufacturer's instructions.

Avertissement

Alimentation • Ne faire fonctionner ce matériel qu'avec une source d'alimentation indiquée sur l'appareil. Ce matériel doit être utilisé avec une alimentation principale comportant un fil de terre (neutre). Le troisième contact (de mise à la terre) constitue un dispositif de sécurité : n'essayez pas de le contourner ni de le désactiver.

Déconnexion de l'alimentation • Pour mettre le matériel hors tension sans danger, déconnecter tous les cordons d'alimentation de l'arrière de l'appareil ou du module d'alimentation de bureau (s'il est amovible) ou encore de la prise secteur.

Protection du cordon d'alimentation • Acheminer les cordons d'alimentation de manière à ce que personne ne risque de marcher dessus et à ce qu'ils ne soient pas écrasés ou pincés par des objets.

Réparation-maintenance • Faire exécuter toutes les interventions de réparation-maintenance par un technicien qualifié. Aucun des éléments internes ne peut être réparé par l'utilisateur. Afin d'éviter tout danger d'électrocution, l'utilisateur ne doit pas essayer de procéder lui-même à ces opérations car l'ouverture ou le retrait des couvercles risquent de l'exposer à de hautes tensions et autres dangers.

Fentes et orifices • Si le boîtier de l'appareil comporte des fentes ou des orifices, ceux-ci servent à empêcher les composants internes sensibles de surchauffer. Ces ouvertures ne doivent jamais être bloquées par des objets.

Lithium Batterie • Il a danger d'explosion s'il y a remplacement incorrect de la batterie. Remplacer uniquement avec une batterie du même type ou d'un type équivalent recommandée par le constructeur. Mettre au rebut les batteries usagées conformément aux instructions du fabricant.

Vorsicht

Stromquellen • Dieses Gerät sollte nur über die auf dem Produkt angegebene Stromquelle betrieben werden. Dieses Gerät wurde für eine Verwendung mit einer Hauptstromleitung mit einem geerdeten (neutralen) Leiter konzipiert. Der dritte Kontakt ist für einen Erdschluss, und stellt eine Sicherheitsfunktion dar. Dieses sollte nicht umgangen oder außer Betrieb gesetzt werden.

Stromunterbrechung • Um das Gerät auf sichere Weise vom Netz zu trennen, sollten Sie alle Netzkabel aus der Rückseite des Gerätes, aus dem externen Stromversorgung (falls dies möglich ist) oder aus der Wandsteckdose ziehen.

Schutz des Netzkabels • Netzkabel sollten stets so verlegt werden, daß sie nicht im Weg liegen und niemand darauf treten kann oder Objekte darauf- oder unmittelbar dagegen gestellt werden können.

Wartung • Alle Wartungsmaßnahmen sollten nur vom qualifiziertem Servicepersonal durchgeführt werden. Die internen Komponenten des Gerätes sind wartungsfrei. Zur Vermeidung eines elektrischen Schocks versuchen Sie in keinem Fall, dieses Gerät selbst öffnen, da beim Entfernen der Abdeckungen die Gefahr eines elektrischen Schlags und/oder anderer Gefahren bestehen.

Schlitze und Öffnungen • Wenn das Gerät Schlitze oder Löcher im Gehäuse aufweist, dienen diese zur Vermeidung einer Überhitzung der empfindlichen Teile im Inneren. Diese Öffnungen dürfen niemals von anderen Objekten blockiert werden.

Litium-Batterie • Explosionsgefahr, falls die Batterie nicht richtig ersetzt wird. Ersetzen Sie verbrauchte Batterien nur durch den gleichen oder einen vergleichbaren Batterietyp, der auch vom Hersteller empfohlen wird. Entsorgen Sie verbrauchte Batterien bitte gemäß den Herstelleranweisungen.

Advertencia

Alimentación eléctrica • Este equipo debe conectarse únicamente a la fuente/tipo de alimentación eléctrica indicada en el mismo. La alimentación eléctrica de este equipo debe provenir de un sistema de distribución general con conductor neutro a tierra. La tercera pata (puesta a tierra) es una medida de seguridad, no puentearla ni eliminarla.

Desconexión de alimentación eléctrica • Para desconectar con seguridad la conectada de alimentación eléctrica al equipo, desenchufar todos los cables de alimentación en el panel trasero del equipo, o desenchufar el módulo de alimentación (si fuera independiente), o desenchufar el cable del receptáculo de la pared.

Protección del cables de alimentación • Los cables de alimentación eléctrica se deben instalar en lugares donde no sean pisados ni apretados por objetos que se puedan apoyar sobre ellos.

Reparaciones/mantenimiento • Solicitar siempre los servicios técnicos de personal calificado. En el interior no hay partes a las que el usuario debe acceder. Para evitar riesgo de electrocución, no intentar personalmente la reparación/mantenimiento de este equipo, ya que al abrir o extraer las tapas puede quedar expuesto a voltajes peligrosos u otros riesgos.

Ranuras y aberturas • Si el equipo posee ranuras o orificios en su caja/alojamiento, es para evitar el sobrecalentamiento de componentes internos sensibles. Estas aberturas nunca se deben obstruir con otros objetos.

Batería de litio • Existe riesgo de explosión si esta batería se coloca en la posición incorrecta. Cambiar esta batería únicamente con el mismo tipo (o su equivalente) recomendado por el fabricante. Desachar las baterías usadas siguiendo las instrucciones del fabricante.

安全须知 • 中文



这个符号提示用户该设备用户手册中有重要的操作和维护说明。



这个符号警告用户该设备机壳内有暴露的危险电压，有触电危险。

注意

阅读说明书 • 用户使用该设备前必须阅读并理解所有安全和使用说明。

保存说明书 • 用户应保存安全说明书以备将来使用。

遵守警告 • 用户应遵守产品和用户指南上的所有安全和操作说明。

避免追加 • 不要使用该产品厂商没有推荐的工具或追加设备，以避免危险。

警告

电源 • 该设备只能使用产品上标明的电源。设备必须使用有地线的供电系统供电。第三条线（地线）是安全设施，不能不用或跳过。

拔掉电源 • 为安全地从设备拔掉电源，请拔掉所有设备后或桌面电源的电源线，或任何接到市电系统的电源线。

电源线保护 • 妥善布线，避免被踩踏，或重物挤压。

维护 • 所有维修必须由认证的维修人员进行。设备内部没有用户可以更换的零件。为避免出现触电危险不要自己试图打开设备盖子维修该设备。

通风孔 • 有些设备机壳上有通风槽或孔，它们是用来防止机内敏感元件过热。不要用任何东西挡住通风孔。

锂电池 • 不正确的更换电池会有爆炸的危险。必须使用与厂家推荐的相同或相近型号的电池。按照生产厂的建议处理废弃电池。

声明

所使用电源为 A 级产品，在生活环境中，该产品可能会造成无线电干扰。在这种情况下，可能需要用户对干扰采取切实可行的措施。

FCC Class B Notice

This equipment has been tested and found to comply with the limits for a Class B digital device, pursuant to part 15 of the FCC Rules. These limits are designed to provide reasonable protection against harmful interference in a residential installation. This equipment generates, uses, and can radiate radio frequency energy and, if not installed and used in accordance with the instructions, may cause harmful interference to radio communications. However, there is no guarantee that the interference will not occur in a particular installation. If this equipment does cause harmful interference to radio or television reception, which can be determined by turning the equipment off and on, the user is encouraged to try to correct the interference by one or more of the following measures:

- Reorient or relocate the receiving antenna.
- Increase the separation between the equipment and receiver.
- Connect the equipment into an outlet on a circuit different from that to which the receiver is connected.
- Consult the dealer or an experienced radio/TV technician for help.

NOTE

This unit was tested with shielded cables on the peripheral devices. Shielded cables must be used with the unit to ensure compliance.

Important Safety Instructions

- 1) Read these instructions.
- 2) Keep these instructions.
- 3) Heed all warnings.
- 4) Follow all instructions.
- 5) Do not use this apparatus near water.
- 6) Clean only with dry cloth.
- 7) Do not block any ventilation openings. Install in accordance with the manufacturer's instructions.
- 8) Do not install near any heat sources such as radiators, heat registers, stoves, or other apparatus (including amplifiers) that produce heat.
- 9) Do not defeat the safety purpose of the polarized or grounding-type plug. A polarized plug has two blades with one wider than the other. A grounding type plug has two blades and a third grounding prong. The wide blade or the third prong are provided for your safety. If the provided plug does not fit into your outlet, consult an electrician for replacement of the obsolete outlet.
- 10) Protect the power cord from being walked on or pinched particularly at plugs, convenience receptacles, and the point where they exit from the apparatus.
- 11) Only use attachments/accessories specified by the manufacturer.
- 12)  Use only with the cart, stand, tripod, bracket, or table specified by the manufacturer, or sold with the apparatus. When a cart is used, use caution when moving the cart/apparatus combination to avoid injury from tip-over.
- 13) Unplug this apparatus during lightning storms or when unused for long periods of time.
- 14) Refer all servicing to qualified service personnel. Servicing is required when the apparatus has been damaged in any way, such as power-supply cord or plug is damaged, liquid has been spilled or objects have fallen into the apparatus, the apparatus has been exposed to rain or moisture, does not operate normally, or has been dropped.

Quick Start Guide — MPA 152 Amplifier

To install and set up an MPA 152 Mini Power Amplifier, follow these steps:

Step 1

Turn all of the equipment off and disconnect it from power sources.

Step 2

Mount the MPA 152 on a rack, under a desk, or on a projector, as illustrated below.

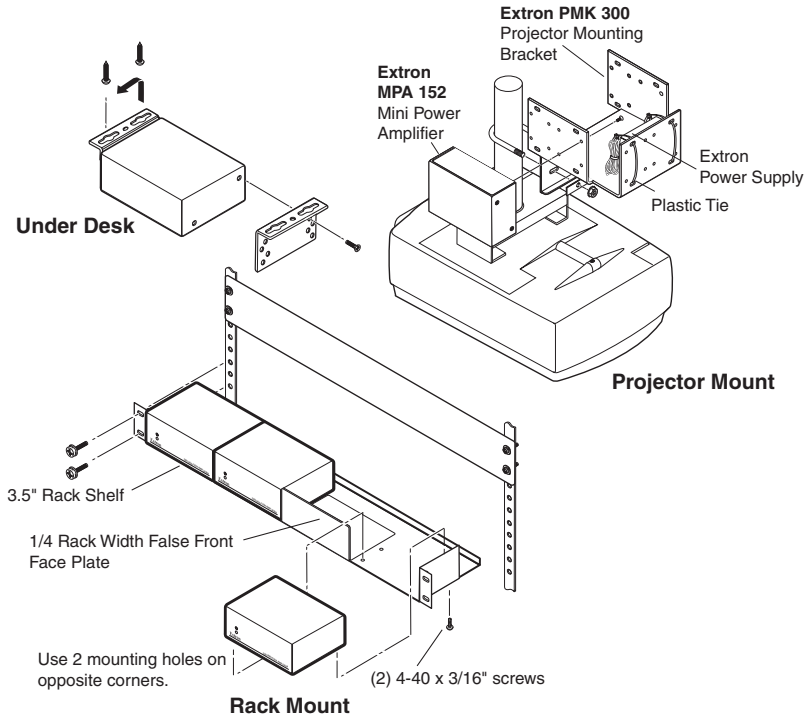

Step 3

Attach the speakers to the MPA 152.

Step 4

Attach inputs to the MPA 152 unit from the audio source and/or projector. Ensure that the projector's audio output is set to **variable out**. Multiple input options can be used simultaneously and result in audio mixing (see "Audio Inputs" in Chapter 2 for more information).

Quick Start Guide — MPA 152 Amplifier, cont'd

NOTE

The MPA 152 amplifier mixes all right channel inputs to a single signal and all left channel inputs to a second signal. The user may output these signals as stereo or sum them to produce a dual mono signal.

Step 5

Connect power cords to MPA 152 and other audio equipment.

Step 6

Adjust the MPA 152 Plus input level, bass and treble.

- If connecting the amplifier to a projector, set the projector volume to its lowest point. Then adjust the MPA 152 level potentiometer fully counter clockwise.

- Set the projector volume to its maximum volume level (no sound should come out).
- Return to the MPA 152 and raise the level until sound distortion first occurs, then lower slightly until the distortion disappears. This setting ensures that, whatever the projector volume setting may be, no clipping occurs.
- Adjust bass and treble to preference.

MPA 152
MINI POWER AMPLIFIER

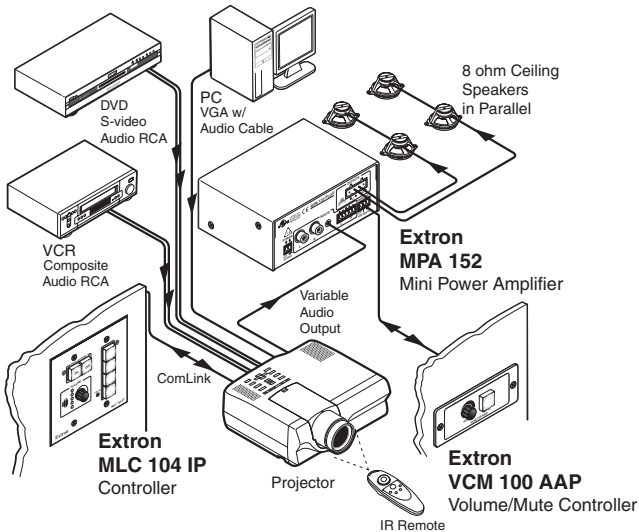

Table of Contents

Chapter One • Introduction	1-1
About this Manual	1-2
About the MPA 152.....	1-2
MPA 152 Features	1-3
Chapter Two • Installation	2-1
Mounting the MPA 152	2-2
Rack mounting	2-2
UL guidelines for rack mounting.....	2-2
Rack mounting procedures	2-3
Tabletop placement	2-3
Projector mounting.....	2-4
Plenum placement	2-5
Under-furniture mounting	2-6
MPA 152 Front Panel Features	2-8
MPA 152 Rear Panel Features	2-9
Power connector.....	2-10
Audio inputs.....	2-11
Remote control.....	2-12
Wiring for remote control.....	2-12
Controlling multiple amplifiers with one volume controller.....	2-13
Audio output.....	2-14
Chapter Three • Operation	3-1
Setting Up the MPA 152 Amplifier	3-2
Setting input level	3-2
Setting bass and treble.....	3-2
Remote Control Options	3-3
Appendix A • Reference Information	A-1
Specifications	A-2
Included Parts	A-4
Accessories	A-5

All trademarks mentioned in this manual are the properties of their respective owners.

68-1320-01

Rev. A

02 09

Table of Contents, cont'd



MPA 152 Amplifier

1

Chapter One

Introduction

About this Manual

About the MPA 152

MPA 152 Features

Introduction

About this Manual

This manual contains information about the Extron MPA 152 Mini Power Amplifier, with instructions on how to mount, install, and operate the unit.

About the MPA 152

The Extron MPA 152 is a high performance, compact, power amplifier.

The amplifier delivers up to 15 watts (rms)/channel stereo or dual mono into a 4 ohm sound system, or 8 watts (rms)/channel into an 8 ohm system.

Front panel controls allow easy adjustment of bass and treble volume and input level.

The unit meets UL smoke and fire code for in-the-ceiling installations and can be stored in the plenum space of the roof.

Alternatively, the units can be mounted on a tabletop, in a rack, under a desk, or in a projector mounting kit.

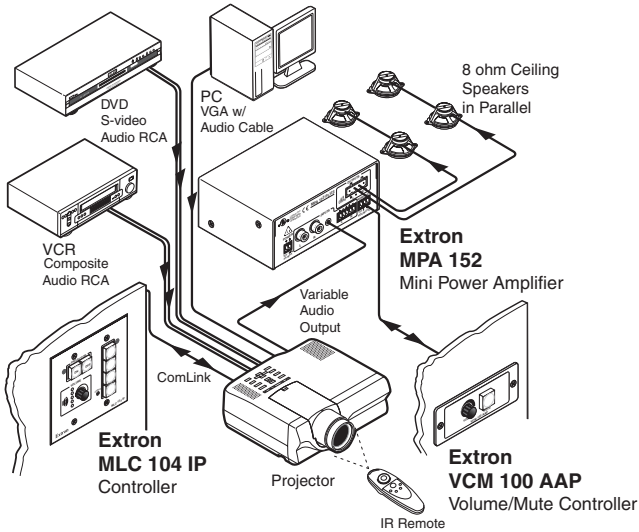

MPA 152 Features

- Class D digital audio amplifier** — For high efficiency and less heat production.
- Ripple Steering technology** — Produces cleaner, low-emission, audio output signals.
- Fixed switching frequency** — Switches at a frequency below the AM band, which reduces the chance of radio interference.
- Three audio inputs** — Accepts 1 balanced/unbalanced input pair (captive screw) and 2 unbalanced pairs (RCA and TRS), providing up to three right and three left channel inputs. All three right inputs are mixed to produce a single right output; all three left outputs are mixed to produce a single left output.
- Stereo/Dual Mono toggle switch** — Allows the user to choose between stereo output or to sum the left and right outputs and produce dual mono outputs.
- Up to 15 watts (rms)/channel stereo output** — Delivers up to 15 watts (rms)/channel, stereo or dual mono, into a 4 ohm speaker system or up to 8 watts (rms)/channel into an 8 ohm system.
- Front panel controls** — Input level, bass and treble are easily adjusted from the front panel.
- Quick-plug speaker outputs** — Speaker output is on a captive screw connector for quick installation.
- Volume and mute remote control** — A rear panel, three-pin captive screw remote input connector allows remote adjustment of volume and muting.
- Always-on clip limiting** — Reduces gain automatically to prevent amplifier clipping.
- Compact size** — The amplifiers are housed in a 1U high, quarter rack 3" deep, metal enclosure, which offers flexible mounting options.
- UL 2043 plenum rated** — The MPA 152 meets UL 2043 requirements for heat and smoke release and is suitable for in-the-ceiling installations, allowing the unit to be stored out of sight, with reduced risk of theft.

CAUTION

Although the amplifier is plenum rated, the power supply provided with it is not. The power supply must not be placed in the plenum space. All cables connected to the amplifier must be plenum rated.



MPA 152 Amplifier

2

Chapter Two

Installation

Mounting the MPA 152

MPA 152 Front Panel Features

MPA 152 Rear Panel Features

Installation

Mounting the MPA 152

The MPA 152 amplifier meets UL 2043 requirements for heat and smoke release and is suitable for in-the-ceiling installations, allowing the unit to be stored out of sight with reduced risk of theft. Alternatively, the 1 U, quarter rack size of these amplifiers allows them to be mounted in a variety of convenient locations:

- Rack
- Tabletop
- Projector
- Under furniture

Rack mounting

UL guidelines for rack mounting

The following Underwriters Laboratories (UL) guidelines are relevant to the safe installation of the MPA 152 in a rack:

1. **Elevated operating ambient temperature** — If the unit is installed in a closed or multi-unit rack assembly, the operating ambient temperature of the rack environment may be greater than room ambient temperature. Therefore, install the equipment in an environment compatible with the maximum ambient temperature (T_{ma}: +122 °F, +50 °C) specified by Extron.
2. **Reduced air flow** — Install the equipment in the rack so that the equipment gets adequate air flow for safe operation.
3. **Mechanical loading** — Mount the equipment in the rack so that uneven mechanical loading does not create a hazardous condition.
4. **Circuit overloading** — Connect the equipment to the supply circuit and consider the effect that circuit overloading might have on overcurrent protection and supply wiring. Give appropriate consideration to the equipment nameplate ratings.
5. **Reliable earthing (grounding)** — Maintain reliable grounding of rack-mounted equipment. Pay particular attention to supply connections other than direct connections to the branch circuit (such as power strips).

Rack mounting procedures

The unit can be mounted in the front or rear of any of these rack systems:

- RSU 126 — 6" deep 1U rack shelf kit (PN 60-190-10)
- RSB 126 — 6" deep 1U basic rack shelf (PN 60-604-11)
- RSU 129 — 9.5" deep 1U rack shelf kit (PN 60-190-01)
- RSB 129 — 9.5" deep 1U basic rack shelf (PN 60-604-02)

To rack mount the MPA 152, follow these directions:

1. If necessary, remove rubber feet from the bottom of the unit.
2. Secure the MPA 152 to the shelf with two 4-40 x 3/16" screws in opposite corners of the base (see figure 2-1 below).
3. Install false faceplate(s) or other unit(s) to the rack shelf.
4. Attach the shelf to the rack with the four provided 10-32 x 3/4" bolts.

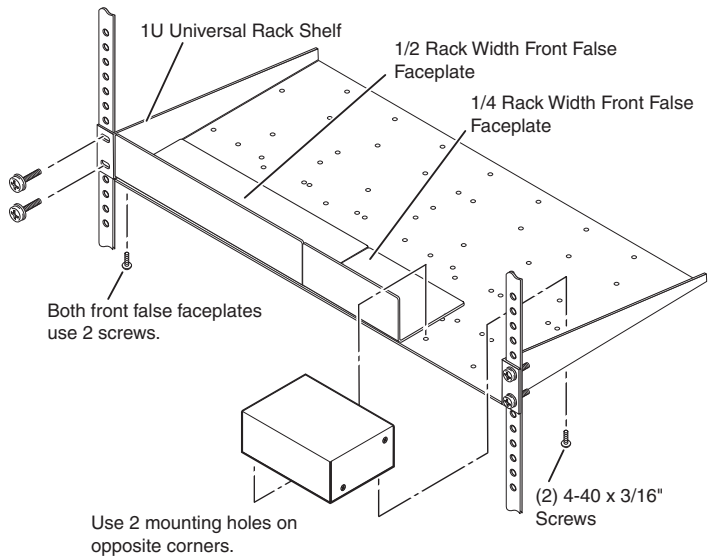

Figure 2-1 — Rack mounting

Tabletop placement

Attach the four provided rubber feet to the bottom of the unit and place it in any convenient location.

Projector mounting

The instructions for mounting the amplifier near the projector, using the PMK 300 projector mounting kit (PN 70-374-01), are shown below. For instructions on using other Extron projector mounting kits, consult the user guide for that kit.

1. If necessary, remove the rubber feet from the bottom of the MPA 152.
2. Mount the receiver to any of the bracket's three mounting plates. The unit should be vertically mounted with the rear panel, housing the input and output connectors, facing downwards.

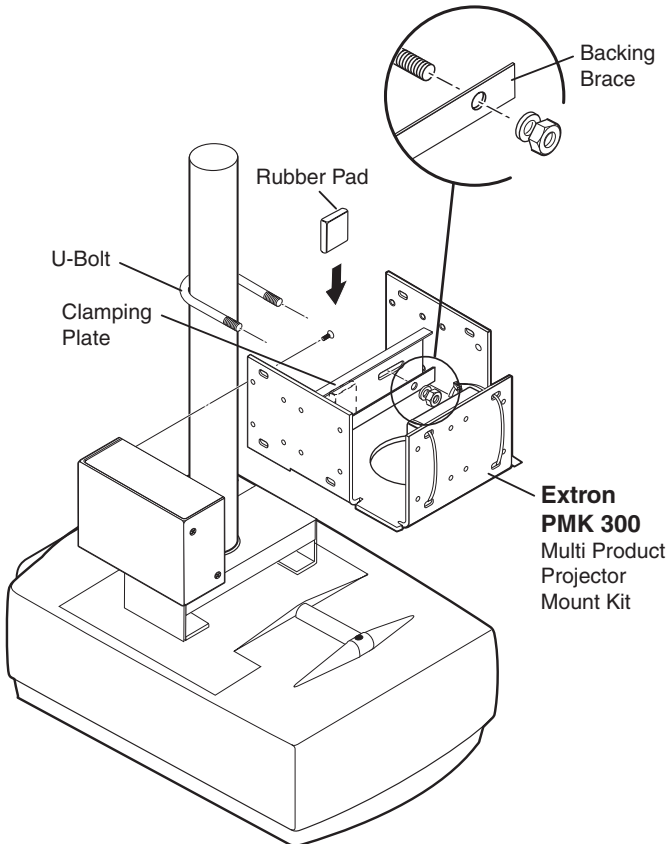

Figure 2-2 — Projector mounting

NOTE

On the side mounting plates, the device is typically mounted on the outside of the bracket. On the front mounting plate, the device is mounted on the inside of the bracket.

-
- a. Use the two 4-40 x 3/16" screws (provided) to secure the amplifier to the bracket
 - b. If required, secure the power supply using the plastic ties provided with the kit.

NOTE

The projector pole can be clamped to the back surface of the clamping plate on the PMK 300, as shown in the figure on the previous page.

Alternatively, the PMK 300 has a hole in the bottom plate that allows the projector pole to be inserted through the center of the plate. In this configuration, slide the PMK 300 up from the bottom of the pole before the projector is installed.

3. Attach the rubber pad to the surface of the clamping plate that will be in contact with the pole.
4. Place the U-bolt around the projector pole and insert the two ends through the slotted holes in the clamping plate and then through the round holes in the backing brace.

NOTE

The provided U-bolt fits a pole with an external diameter of 1.5" to 2.0". For larger or smaller diameter poles, obtain a U-bolt from a local hardware store. The slotted holes in the clamping plate can accommodate U-bolts that are 1.0" to 2.5" in width.

5. Secure the bracket to the projector pole with the U-bolt and the provided hex nuts and washers. Use an appropriately-sized socket wrench to tighten the hex nuts.

Plenum placement

The MPA 152 meets UL 2043 requirements for heat and smoke release and can be installed in the ceiling plenum space.

CAUTION

Although the amplifier is plenum rated, the power supply provided with it is not. The power supply must not be placed in the plenum space. All cables connected to the amplifier must be plenum rated.

Installation, cont'd

Under-furniture mounting

The MPA 152 amplifier can be mounted under furniture using the optional MBU 123 mounting kit (PN 70-212-01):

1. Attach the mounting brackets to the MPA 152 with the provided machine screws as shown in the figure below.
2. Hold the amplifier with the attached brackets against the underside of the table or other furniture. Mark the location of the screw holes of the bracket on the mounting surface.
3. Drill $3/32$ " (2 mm) diameter pilot holes, $1/4$ " (6.3 mm) deep in the mounting surface at the marked locations.
4. Insert #8 wood screws into the four pilot holes. Tighten each screw into the mounting surface until just less than $1/4$ " of the screw head protrudes.
5. Align the amplifier so that the screw heads pass through the slots in the brackets and the unit is resting firmly against the bottom surface of the furniture.

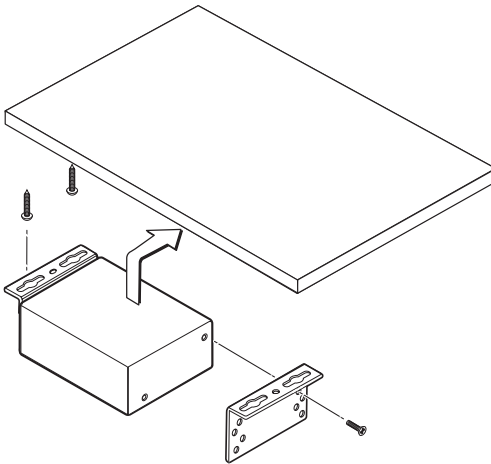

Figure 2-3 — Under furniture mounting

6. Slide the unit slightly forward or back. Tighten all four screws to secure it in place.



MPA 152 Front Panel Features

The illustration below shows the front panel of the MPA 152.

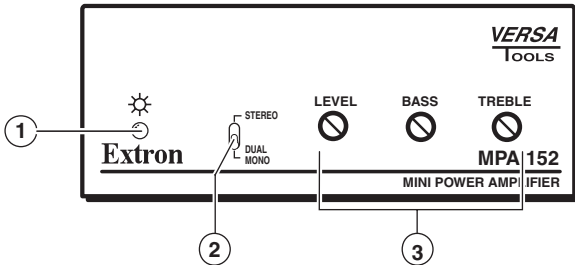

Figure 2-4 — MPA 152 Front Panel Features

- ① **Power LED** — The green LED is lit when the unit receives power.
- ② **Stereo/Dual Mono toggle switch** — Allows the user to choose between stereo output for stereo program speakers or dual mono output for mono ceiling speakers
- ③ **Potentiometers** — Three front panel potentiometers are used to optimize level, bass, and treble settings.

MPA 152 Rear Panel Features

The illustration below shows the rear panel of the MPA 152.

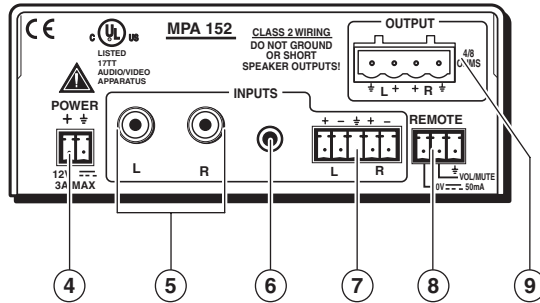

Figure 2-5 — MPA 152 Rear Panel Features

- ④ **Power connector** — Connect the 12 V external power supply to the amplifier using the 2-pole captive screw connector
- ⑤ **RCA input connectors** — These female RCA connectors accept line level, mono or stereo, audio sources.
- ⑥ **3.5 mm stereo input** — This input accepts a 3.5 mm tip-ring-sleeve (TRS) stereo jack.
- ⑦ **Balanced or unbalanced audio input connector** — Connect balanced or unbalanced, mono or stereo, audio to this 5-pole, 3.5 mm captive screw connector.
- ⑧ **Remote input connector** — This 3-pole 3.5 mm captive screw connector allows remote control of volume or muting of audio.
- ⑨ **Speaker connector** — Connect the speakers to this socket using quick-plug 4-pole, 5 mm captive screw connector.

Installation, cont'd

Power connector

Connect the two pole, 3.5 mm captive screw connector from the power supply (provided) to this socket on the rear panel. Ensure the connections have the correct polarity as shown in the illustration below:

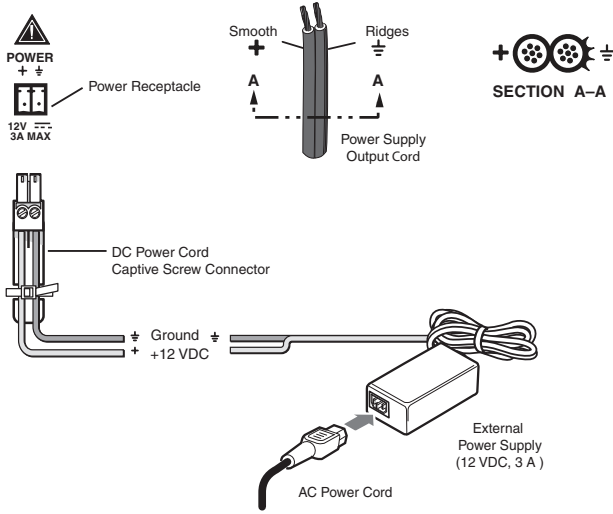

Figure 2-6 — Connecting power

NOTE

The length of the exposed wires in the stripping process is critical. The ideal length is 3/16" (5 mm). Any longer and the exposed wires may touch, causing a short circuit between them. Any shorter and the wires can be easily pulled out even if tightly fastened by the captive screws.

CAUTION

Do not tin the wires. Tinned wire does not hold its shape and can become loose over time.

Audio inputs

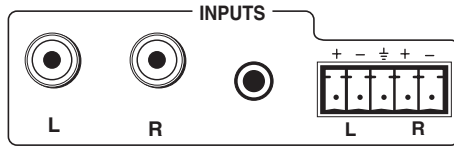
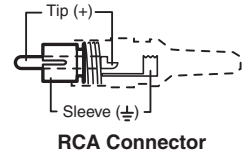
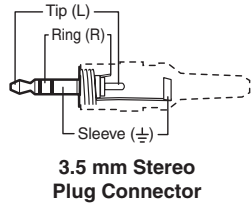

Figure 2-7 — Audio inputs

RCA connectors — Two connectors (left and right) accept unbalanced, line level audio signals. The input can be stereo (using two RCA jacks) or mono (using a single RCA jack plugged into the left/mono socket). If unused, the connectors automatically terminate to lower the noise floor.



3.5 mm TRS connector — This connector accepts unbalanced, line level audio signals. If unused, the connector automatically terminates to lower the noise floor.



Captive Screw connector — This 5-pole, 3.5 mm captive screw input accepts balanced or unbalanced, mono or stereo, line level signals.

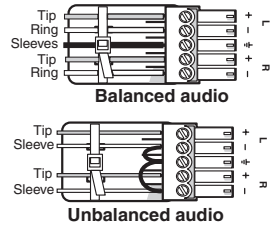

NOTE

The length of the exposed wires in the stripping process is critical. The ideal length is 3/16" (5 mm). Any longer and the exposed wires may touch, causing a short circuit between them. Any shorter and the wires can be easily pulled out even if tightly fastened by the captive screws.

CAUTION

Do not tin the wires. Tinned wire does not hold its shape and can become loose over time.

The three left channel inputs (RCA, TRS and captive screw) and three right channels are mixed to provide a single left channel output. The three right channel inputs are mixed to provide a single right channel output.

Depending on the position of the front panel toggle switch, the right and left channels may be output as a stereo signal, or summed and output as a dual mono signal.

Installation, cont'd

Remote control

Wiring for remote control

This 3-pin, captive screw connector allows a wall-mounted audio controller or MediaLink product to control volume and mute levels remotely.

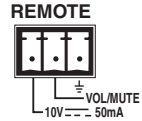

Options for remote control include Extron's VC 50 (PN 70-530-02), VCM 100 AAP (PN 70-396-x1), VCM 100 MAAP (PN 70-397-x1) and MLA VC10 (PN 60-502-01).

Third party 10k potentiometer volume controllers can also be connected to this port.

NOTE *The length of the exposed wires in the stripping process is critical. The ideal length is 3/16" (5 mm). Any longer and the exposed wires may touch, causing a short circuit between them. Any shorter and the wires can be easily pulled out even if tightly fastened by the captive screws.*

CAUTION *Do not tin the wires. Tinned wire does not hold its shape and can become loose over time.*

Wire the the remote control connector to the VCM 100 MAAP as shown in the figure and instructions below:

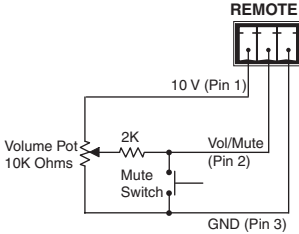

Figure 2-8 — Wiring diagram for remote control

- Pin 1 is 10 V DC reference voltage.
- Pin 2 (VOL/MUTE) has two functions:
 - a. It can be used as a variable voltage input. The volume control range DC voltage range is 0 to 10 V, with 0 V giving full attenuation and 10 V giving maximum volume.
 - b. It can be used for remote control muting. Sound is muted while the mute pin is shorted to ground.
- Pin 3 is ground.

NOTE *All nominal levels are at $\pm 10\%$*

Controlling multiple amplifiers with one volume controller

Several MPA 152 units can be daisy-chained so that one volume controller can simultaneously regulate the volume of all the amplifiers.

NOTE *As additional amplifiers are added to the daisy chain, the sensitivity of the volume potentiometer will change. The maximum volume level (fully clockwise) will not be affected. However the effectiveness of the minimum volume level (fully counterclockwise) in reducing the volume to inaudible levels decreases as more amplifiers are added to the daisy chain.*

NOTE *When more than two MPAs are attached to the chain, sound may begin to be heard even if the levels have been set to their lowest. The muting of the output however can be remedied with a contact closure button attached between the Vol/Mute and Ground pin of the first MPA in the chain.*

To regulate multiple amplifiers with a single volume controller, follow these instructions:

1. Attach all three pins of the volume controller to the corresponding pins on the first MPA 152 unit only (ground to ground; Mute/Vol to Mute/Vol; and 10 V to 10 V).
2. Use jumper wires to connect the Vol/Mute pins of the first and each successive amplifier.
3. Use jumper wires to connect the ground pins of the first and each successive amplifier.

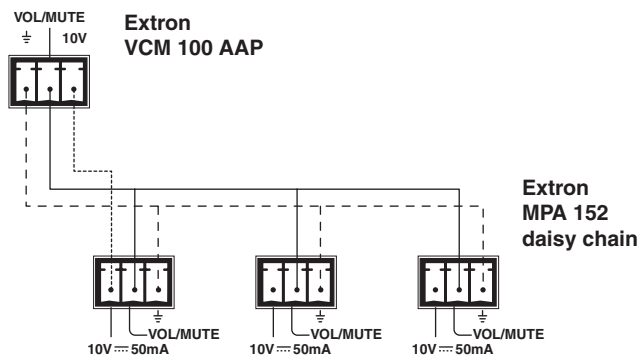

Figure 2-9 — Controlling multiple amplifiers with one volume controller

Installation, cont'd

Audio output

This 4-pole, 5 mm captive screw connector is used to connect the amplifier to the speakers.

All right channel input signals are mixed and summed to produce a single, right channel output; likewise, all left channel input signals are mixed and summed to produce a single, left channel output

If the front panel switch is set to stereo, the output will be stereo; if the front panel switch is set to mono, the right and left channels will be mixed and summed for a dual mono output.

With an 8 ohm load, the amplifier produces up to 8 watts/channel. With a 4 ohm load, the amplifier produces up to 15 watts per channel.

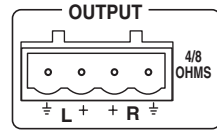

CAUTION

Do not short the + and - outputs to each other, as this will damage the amplifier.

NOTE

The length of the exposed wires in the stripping process is critical. The ideal length is 3/16" (5 mm). Any longer and the exposed wires may touch, causing a short circuit between them. Any shorter and the wires can be easily pulled out even if tightly fastened by the captive screws.

CAUTION

Do not tin the wires. Tinned wire does not hold its shape and can become loose over time.



MPA 152 Amplifier

3 Chapter Three

Operation

Setting up the MPA 152 Amplifier

Remote Control Options

Operation

Setting Up the MPA 152 Amplifier

Setting input level

Adjust the MPA 152 input level, bass as follows:

1. Unplug the remote plug from the unit.
2. Turn the level potentiometer fully counterclockwise.
3. Set the volume of the audio source to its maximum level. No sound should come out.
4. Slowly increase the MPA 152 level until sound distortion starts to occur. Lower the level slightly until the distortion disappears. This setting will ensure that, whatever the volume setting of the audio source, no clipping will occur.

Setting bass and treble

Adjust the MPA 152 bass and treble as follows:

1. Use the bass potentiometer to increase or decrease the bass shelving ± 10 dB at 100 Hz and below.
2. Use the treble potentiometer to increase or decrease the bass shelving ± 10 dB at 10 kHz and above.

NOTE

Turning the bass or treble potentiometers counterclockwise will decrease the output at the specified frequencies. Turning the potentiometers clockwise will increase the output. When the potentiometer is at the center detent, flat response is achieved.

Remote Control Options

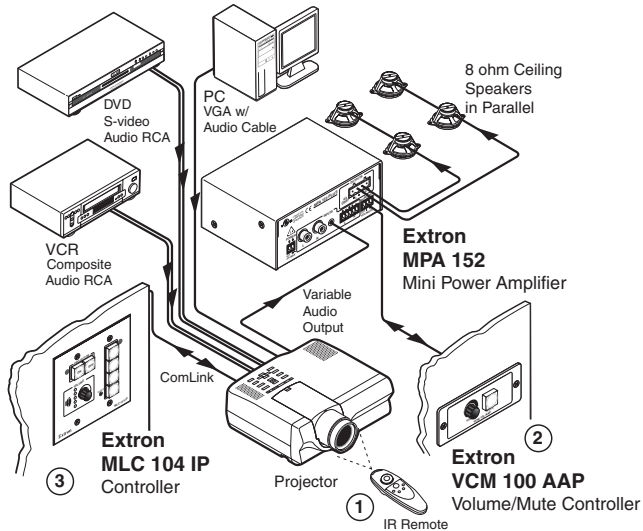

Figure 3-1 — Remote Control Options

- ① **Using the projector's IR remote** — For a projector with variable audio outputs, connect the projector audio output to the MPA 152 audio input. Use the projector's IR remote to control the projector's volume, which effectively controls the volume of the MPA 152.
- ② **Extron VCM 100 AAP volume and mute control** — There are a variety of options for a projector without variable audio outputs, or for a system designed to control MPA 152 volume directly. See page 2-12 for more information.
- ③ **Using a MediaLink™ Controller** — For a projector with variable audio output, connect the projector audio output to the MPA 152 audio input. Use a MediaLink controller to adjust the projector's volume via RS-232. MediaLink controllers can also use IR remote to adjust the projector's volume and thus the input to the amplifier.



MPA 152 Amplifier

A

Appendix A

Reference Information

Specifications

Included Parts

Accessories

Reference Information

Specifications

Audio

Gain

Balanced	25x (28 dB)
Unbalanced	50x (34 dB)
Stereo channel separation	>60 dB @ 1 kHz
CMRR.....	74 dB @ 1 kHz
Bass adjustment.....	± 10 dB @ 80 Hz (reference) to 1 kHz (2 dB tolerance)
Treble adjustment.....	± 10 dB @ 10 kHz (reference) to 1 kHz (2 dB tolerance)

Audio input

Number/Signal Type.....	1 stereo, balanced/unbalanced input 2 stereo, unbalanced inputs (The three inputs are individually buffered and mixed together.)
Connectors	(1) 3.5 mm captive screw connector, 5 pole (main input) (1) 3.5 mm mini audio jack (tip, ring, sleeve) 1 pair RCA
Impedance.....	> 10k ohms, balanced/unbalanced, DC coupled
Nominal level	+4 dBu (1.23 Vrms) balanced or -10 dBV (316 Vrms) unbalanced
Maximum level.....	-3 dBV (unbalanced), +3 dBV (balanced) at 1% THD+N
Input level sensitivity	
Balanced	-10 dBV
Unbalanced	-16 dBV

NOTE $0\text{ dBu} = 0.775\text{ Vrms}$, $0\text{ dBV} = 1\text{ Vrms}$, $0\text{ dBV} \approx 2\text{ dBu}$

Audio output

Number/Signal type	1 stereo or 2 mono (2 channels total)
Connectors	(1) 5 mm captive screw connector, 4 pole
Minimum load impedance	4 ohms
Amplifier Type.....	Class D

Output power	8 watts (rms) per channel, 8 ohms, 1 kHz, < 1% THD 15 watts (rms) per channel, 4 ohms, 1 kHz, < 1% THD
Frequency Response	20 Hz to 20 kHz, ± 3 dB @ 1 watt output
THD + Noise	0.15% @ 1 kHz at nominal level (1 watt, 8 ohm load)
S/N	74 dB @ 20 Hz to 20 kHz at maximum output (unweighted with balanced input)
Damping factor	>30 (with a 4 ohm load)

Control/remote — amplifier

Control port	(1) 3.5 mm captive screw connector, 3 pole
Pin configuration	Pin 1 = +10 VDC, 50 mA (max.), Pin 2 = volume/mute (variable voltage), Pin 3 = GND
Volume control voltage range	0 V (mute) to 10 V (maximum volume)

General

External power supply	100 VAC to 240 VAC, 50/60 Hz, external; to 12 VDC, 3 A (max.), regulated
Power input requirement	12 VDC, up to 3A
Temperature/humidity	Storage: -40 to +158 °F (-40 to +70 °C)/ 10% to 90%, noncondensing Operating: +32 to 122 °F (0° to 50 °C)/ 10% to 90%, noncondensing
Cooling	Convection, no vents
Mounting	
Rack mount	Yes, with optional 1U, 9.5" deep rack shelf (RSU 129, # 60-190-01; or RSB 129, #60-604-01); 1U, 6" deep rack shelf (RSU 126, # 60-190-10; or RSB 126, #60-604-10); or VersaTools® 1U, 3.5" deep rack shelf (RSF 123, #60-190-20; or RSB 123 #60-604-20)
Furniture mount	Yes, with optional VersaTools® MBU 123 mini under-desk mounting kit (#70-212-01)
Projector mount	Above-projector mountable with optional PMK 300 Multi-Product Projector Mounting Kit (#70-374-01)
Enclosure type	Metal

Reference Information, cont'd

Enclosure dimensions.....	1.7" H x 4.3" W x 3" D (1U high, quarter rack wide) (4.3 cm H x 10.9 cm W x 7.6 cm D) (Depth excludes connectors.)
Product weight	0.6 lbs (0.3 kg)
Shipping weight	3 lbs (2 kg)
Vibration	ISTA 1A in carton (International Safe Transit Association)
Regulatory Compliance	
Safety.....	CE, CUL, UL UL rated for use in plenum airspaces; meets UL 2043 for heat and smoke release, excluding the power supply; meets UL 60065 for safety.
EMI/EMC	CE, C-tick, FCC Class B, ICES, VCCI
MTBF.....	30,000 hours
Warranty.....	3 years parts and labor

NOTE All nominal levels are at $\pm 10\%$

NOTE Specifications are subject to change without notice.

Included Parts

These items are included in each order for an MPA 152:

Included parts	Replacement part number
MPA 152	60-844-01
External 12 V DC, 3 A power supply	
IEC power cord	
(1) 4-pole 5 mm terminal block plug	
(1) 5-pole 3.5 mm captive screw plug	
(1) 3-pole 3.5 mm captive screw plug	
(1) 2-pole 3.5 mm power captive screw plug	
Setup Guide — MPA 152	

Accessories

Accessories	Part number
MBB 100 Back of rack mounting kit	70-367-01
MBU 123 Mini under-desk mounting kit	70-212-01
PMK 300 Projector mounting kit	70-374-01
PMK 450 Projector mounting kit	70-618-03
RSB 123 (3.5" deep, 1U basic rack shelf)	60-604-20
RSF 123 (3.5" deep, 1U rack shelf kit)	60-190-20
RSB 126 (6" deep, 1U basic rack shelf)	60-604-10
RSU 126 (6" deep, 1U rack shelf kit)	60-190-10
RSB 129 (9.5" deep, 1U basic rack shelf)	60-604-01
RSU 129 (9.5" deep, 1U rack shelf kit)	60-190-01
VC 50 Volume control wall plate	70-530-02
VCM 100 AAP Volume/mute - AAP	70-396-11
VCM 100 MAAP Volume/mute - MAAP	70-397-11
MLA VC10 Volume control module	60-502-01
SPK 18 Pre-cut speaker cable	26-627-25
SI 3 (Black, White)	42-105-xx
SI 3CT LP ceiling speakers	42-103-03
SI 26 (Black, White)	42-072-xx
SI 26 X	42-067-03

Extron's Warranty

Extron Electronics warrants this product against defects in materials and workmanship for a period of three years from the date of purchase. In the event of malfunction during the warranty period attributable directly to faulty workmanship and/or materials, Extron Electronics will, at its option, repair or replace said products or components, to whatever extent it shall deem necessary to restore said product to proper operating condition, provided that it is returned within the warranty period, with proof of purchase and description of malfunction to:

**USA, Canada, South America,
and Central America:**

Extron USA
1001 East Ball Road
Anaheim, CA 92805
U.S.A.

Europe, Africa, and the Middle East:

Extron Europe
Hanzeboulevard 10
3825 PH Amersfoort
The Netherlands

Asia:

Extron Asia
135 Joo Seng Road #04-01
PM Industrial Bldg.
Singapore 368363
Singapore

Japan:

Extron Japan
Kyodo Building, 16 Ichibancho
Chiyoda-ku, Tokyo 102-0082
Japan

China:

Extron China
686 Ronghua Road
Songjiang District
Shanghai 201611
China

Middle East:

Extron Middle East
Dubai Airport Free Zone
F12, PO Box 293666
United Arab Emirates, Dubai

This Limited Warranty does not apply if the fault has been caused by misuse, improper handling care, electrical or mechanical abuse, abnormal operating conditions or non-Extron authorized modification to the product.

If it has been determined that the product is defective, please call Extron and ask for an Applications Engineer at (714) 491-1500 (USA), 31.33.453.4040 (Europe), 65.6383.4400 (Asia), or 81.3.3511.7655 (Japan) to receive an RA# (Return Authorization number). This will begin the repair process as quickly as possible.

Units must be returned insured, with shipping charges prepaid. If not insured, you assume the risk of loss or damage during shipment. Returned units must include the serial number and a description of the problem, as well as the name of the person to contact in case there are any questions.

Extron Electronics makes no further warranties either expressed or implied with respect to the product and its quality, performance, merchantability, or fitness for any particular use. In no event will Extron Electronics be liable for direct, indirect, or consequential damages resulting from any defect in this product even if Extron Electronics has been advised of such damage.

Please note that laws vary from state to state and country to country, and that some provisions of this warranty may not apply to you.

Extron USA - West

Headquarters

+800.633.9876

Inside USA / Canada Only

+1.714.491.1500**+1.714.491.1517 FAX****Extron USA - East****+800.633.9876**

Inside USA / Canada Only

+1.919.863.1794**+1.919.863.1797 FAX****Extron Europe****+800.3987.6673**

Inside Europe Only

+31.33.453.4040**+31.33.453.4050 FAX****Extron Asia****+800.7339.8766**

Inside Asia Only

+65.6383.4400**+65.6383.4664 FAX****Extron Japan****+81.3.3511.7655****+81.3.3511.7656 FAX****Extron China****+400.883.1568**

Inside China Only

+86.21.3760.1568**+86.21.3760.1566 FAX****Extron Middle East****+971.4.2991800****+971.4.2991880 FAX**